

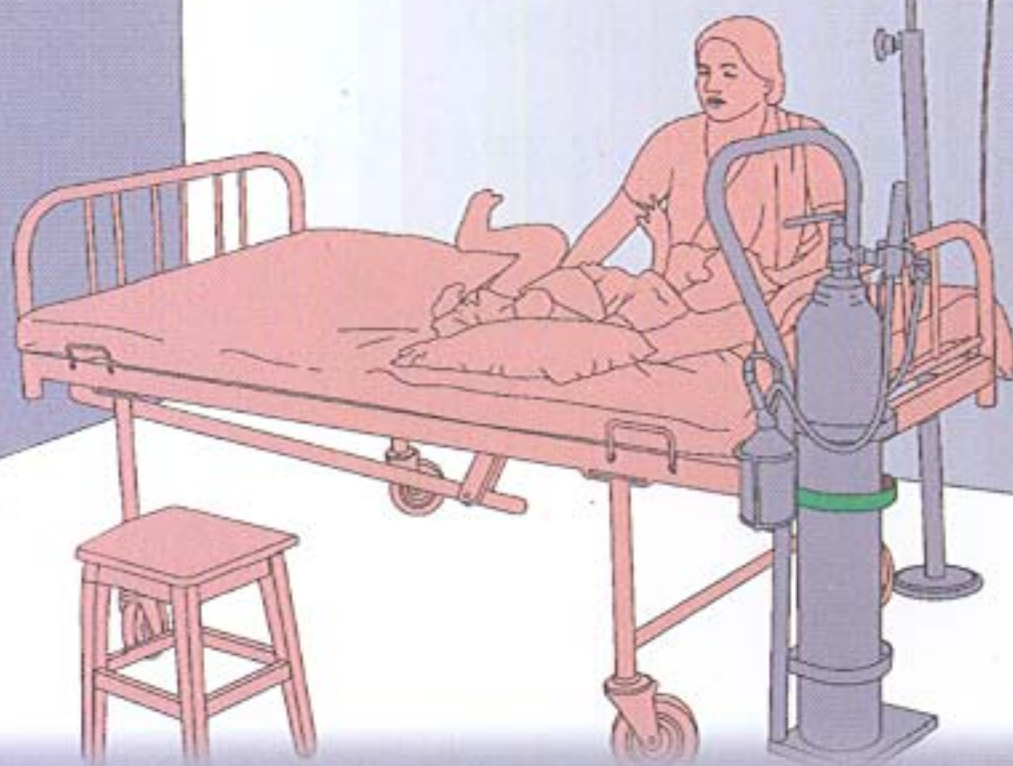

Guidelines on Non-Structural Safety in Health Facilities



His Majesty's Government
Ministry of Health
Department of Health Services
Epidemiology & Disease Control Division
&
WHO Nepal
Teku, Kathmandu, Nepal
March 2004



PREFACE

In 2001, the Ministry of Health (MOH), the World Health Organisation (WHO) and National Society for Earthquake Technology – Nepal (NSET) carried out a study on the structural safety of hospitals in Kathmandu Valley. The aim of the study was to assess the level of vulnerability of the health infrastructure to impending earthquakes. The study found that in the case of a moderate size earthquake most of the assessed hospitals would withstand the earthquake without collapsing. In terms of functionality, though, only 10 % of the hospitals might be fully functional, 30 % partially functional and up to 60 % non-functional. The study also found that the greatest loss of function would be likely to come from damage to the non-structural components. A subsequent study conducted in 2003 focussing on the non-structural vulnerability of 9 hospitals throughout the country found that substantial improvements could be achieved by implementing a range of non-structural mitigation measures.

The *Non-structural Vulnerability Assessment of Hospitals in Nepal*, was commissioned by WHO and the Epidemiology & Disease Control Division / Department of Health Services and carried out by National Society for Earthquake Technology (NSET). NSET not only developed an appropriate methodology for making such assessments but also outlined a range of easy to implement and low cost mitigation measures that the maintenance sections of health facilities could apply in their everyday maintenance work.

The objective of these *Guidelines on Non-Structural Safety in Health Facilities* is to disseminate the above mentioned mitigation measures to as wide an audience as possible. This includes the maintenance staff who can utilise the guideline to adjust their daily maintenance routines as well as hospital managers who can use the guidelines for decision making concerning reduced vulnerability and priority actions.

The contents of the guidelines are: a discussion of the essential role of health services immediately following a medium or large-scale earthquake and an outline of the possible threat to lives and functionality of the health facilities stemming from damage to non-structural components. Based on the 2003 study, the easy to implement, low-cost mitigation measures are introduced and recommended for implementation in the day-to-day maintenance of all health facilities.

All figures, photographs and graphic illustrations in these guidelines are originally made for the publication, *Non-structural Vulnerability Assessment of Hospitals in Nepal*. Sincere thanks must be extended to the earthquake engineers and graphic illustrators of NSET-Nepal, who put an enormous effort into the original assessment and development of the publication on which the present document is based. I would especially like to acknowledge the work and assistance of Mr. Ramesh Guragain and Mr. Bishnu Pandey from NSET, who were instrumental in producing the original report and who also provided important input to these guidelines. I would also like to thank the Disaster Health Working Group for its continuous support and guidance in the field of vulnerability assessment and mitigation of health facilities. Last but not least I would like to acknowledge the effort made by Ms. Trine Ladegaard, Technical Officer and Mr. Umesh Kattel, National Operations Officer from the EHA programme of the WHO Nepal in preparing and editing this publication.



Dr. M. B. Bista,
Director

Epidemiology & Disease Control Division / DHS / MOH



TABLE OF CONTENTS

1. Introduction	1
2. Defining Terminology	3
Structural and Non-Structural Components	3
Causes of Non-Structural Damage	6
3. Non-Structural Vulnerability Mitigation Measures	8
Anchorage	8
Chaining System on Beds	11
Flexible Couplings	12
Hooking	13
Modification	16
Operation Theatres	17
Rapid Response and Repair	18
Redundancy	18
Reinforcement	18
Removal & Relocation	19
Restricted Mobility	21
Strapping	22
Substitution	23
Supports	23
References	24

1. Introduction

Throughout history, it has been demonstrated over and over again that Nepal is a highly earthquake prone country. During the last 700 years, nine major earthquakes have been registered and small-scale tremors shake parts of the country regularly. The last major one to hit Nepal was the Great Bihar-Nepal earthquake in 1934, and it brought immense devastation to buildings and infrastructure as well as affected thousands of lives. If a similar earthquake was to hit the country today, the consequences could be many times worse. This is because the population density of the cities is increasing daily and building practices do not always take seismic safety into consideration. The migration of people into the city areas also means that many vulnerable areas such as riverbanks are becoming populated as other land is not always available or affordable, and this is an added vulnerability.

THE KATHMANDU VALLEY EARTHQUAKE SCENARIO

Based on the damage caused by the shaking level of the Great Bihar Earthquake in 1934, the Kathmandu Valley Earthquake Risk Management Project has made an estimation of the damage a similar level of shaking would produce today. It is a frightening scenario, which indicates 40,000 deaths and 95,000 injured. In addition, more than 60 % of buildings may be destructed, which could leave as many as 600,000 to 900,000 people homeless, and the water and electricity supply could be disrupted for many weeks. Although the scenario estimates the potential damage in the Kathmandu Valley only, all other cities in Nepal face a similar risk depending on building patterns, population density and lifeline systems. The recent earthquake in Bam in Iran in December 2003 demonstrated that the outlined scenario is not unlikely; it left more than 41,000 dead, 30,000 injured and up to 87 % of buildings destroyed in Bam city itself.

Source: NSET, 1999 and UNDAC Mission Report, 2004

In any disaster response, health facilities are expected to play an essential role. This is especially the case when responding to a major earthquake where the number of people sustaining injuries tends to be relatively high and the need for medical care is pronounced immediately after the earthquake.

However, the hospital buildings and occupants may also be victims of the earthquake. This was the case in Bam where three hospitals, 95 health centres and 14 rural clinics were destroyed. The destruction of hospitals not only poses a risk to the lives of the patients and the people working there, but it also puts an even bigger strain on the hospitals that survive. That is why it is not sufficient that a

hospital building withstands the earthquake without collapsing. It must also be functional, which means that all essential equipment and lifeline systems as well as operation theatres and emergency wards must be undamaged, or at least only damaged to the extent that they can still be used.

Consequently, when talking about health facilities, the risk posed by earthquakes to staff and patients, buildings and equipment can be divided into three different types: life safety, loss of function and property loss. The definition is given in the table below.

LIFE SAFETY	LOSS OF FUNCTION	PROPERTY LOSS
<p>People (patients and staff) risk injury and death by damaged or falling elements of buildings, equipment and contents. Broken glass, overturned heavy cabinets and shelves, ruptured gas or electricity lines, falling ceilings and masonry partition walls are all examples of damage that may cause injuries and death.</p>	<p>If essential equipment and wards of the hospital are damaged it can mean a serious disruption of essential services such as emergency wards, operation theatres, x-ray machines and laboratory facilities. Loss of function can also happen due to interrupted life line facilities such as water and electricity and due to fires and water damage.</p>	<p>Contents such as furniture, files, office and medical equipment represent a significant cost in case of medical facilities. Property losses may be caused by direct damage from the earthquake movements or secondary causes such as fire.</p>

The loss of life, function and property can occur in a number of different ways during and immediately following an earthquake. The most obvious threat is building collapse, which will crush and / or trap everything and everybody in the building resulting in high morbidity and mortality as well as complete loss of function. There are, however, other levels of damage, and to understand the typical damage patterns of moderate to large-size earthquakes it is useful to distinguish between different types of building components. This will be the focus of the next chapter.

2. Defining Terminology

Structural and Non-Structural Components

All buildings can be divided into two types of components: Structural and non-structural. These guidelines only focus on the non-structural components as mitigation of risk to the structural components is a complex issue, which requires expert assistance from a structural engineer as well as higher cost involvement. In contrast, much of the risk to non-structural components can be mitigated with relatively low cost and within the existing capacities of the hospital. However, in order to understand and distinguish between the two types of components, a definition of both is given below.

STRUCTURAL	NON-STRUCTURAL
<p>The structural parts of a building are those that resist gravity, earthquakes, wind and other types of loads. They include columns (posts, pillars); beams (girders, joists) and foundations (mat, spread footings, piles). For engineered constructions, the structure is typically designed and analysed in detail by a structural engineer, but for non-engineered constructions, masons or labour contractors generally construct these elements directly without an analysed design.</p>	<p>The non-structural parts of a building include all parts of the building and its contents with the exception of the structure. In other words, everything except the columns, floors, beams etc. Common non-structural components include ceilings; windows; office equipment; computers; inventory; file cabinets; water tanks; generators; transformers; heating, ventilating, and air conditioning (HVAC) equipment; electrical equipment; furnishings; lights etc. Typically, non-structural items are not analyzed by engineers and may be specified by architects, mechanical engineers, electrical engineers, and interior designers. In most cases, they are purchased by the owners after the construction is finished without the involvement of any design professional.</p>

Figure 1 further illustrates the different types of non-structural components in a health facility.

It is important to note that not all types of non-structural vulnerability mitigation are dealt with here. For a more elaborate and detailed overview of a complete plan for reducing both structural and non-structural vulnerability in selected hospitals, see the two publications, *A Structural Vulnerability Assessment of Hospitals in Kathmandu Valley* and *Non-Structural Vulnerability Assessment of Hospitals in Nepal*.

Figure 1: Non-Structural Components in a Hospital

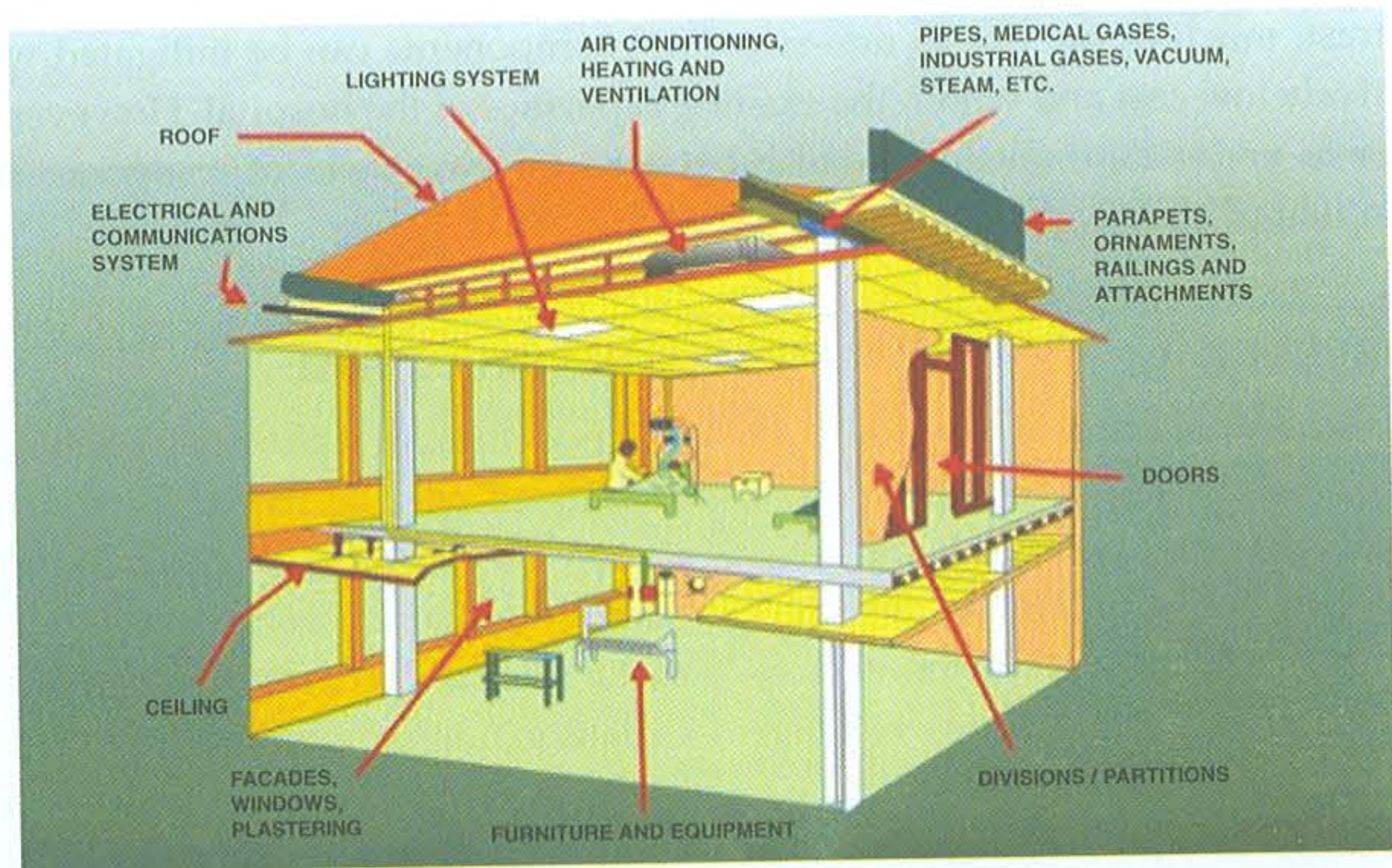

Health facilities, especially hospitals, are complex structures with a diverse range of equipment, furniture and architectural components. In many cases, destruction of essential components can prevent the hospital from functioning properly and from providing the necessary services. In addition to these components, the hospital relies on a set of lifeline systems such as water, electricity, sewerage and communication and these are typically reliant on services provided from outside the hospital such as public water works, telecommunications and public power supply.

Figure 2 illustrates the interrelationship between all the different components of a typical hospital.

In many cases, the public supply system will be disrupted for some time after a large earthquake. The absence of supplies of water, electricity and other essential lifeline systems can seriously hamper the functionality of the health facilities, and this means that the individual facility must ensure that emergency provisions are available. Ideally, all health facilities should have their own backup systems consisting of e.g. emergency generators, wells, and internal communication

systems. All these aspects must be considered when assessing and mitigating the non-structural vulnerability of the facility. Therefore, they must be an integrated part of the hospital or health facility's emergency preparedness and response plan. (For more information regarding emergency planning, please refer to *Guidelines on Emergency Preparedness & Disaster Management for Hospitals*, EDCD / DHS / MOH 2002, and *Health Sector Emergency Preparedness & Disaster Response Plan Nepal*, EDCD / DHS / MOH 2003).

Figure 2: Major Components of the Hospital

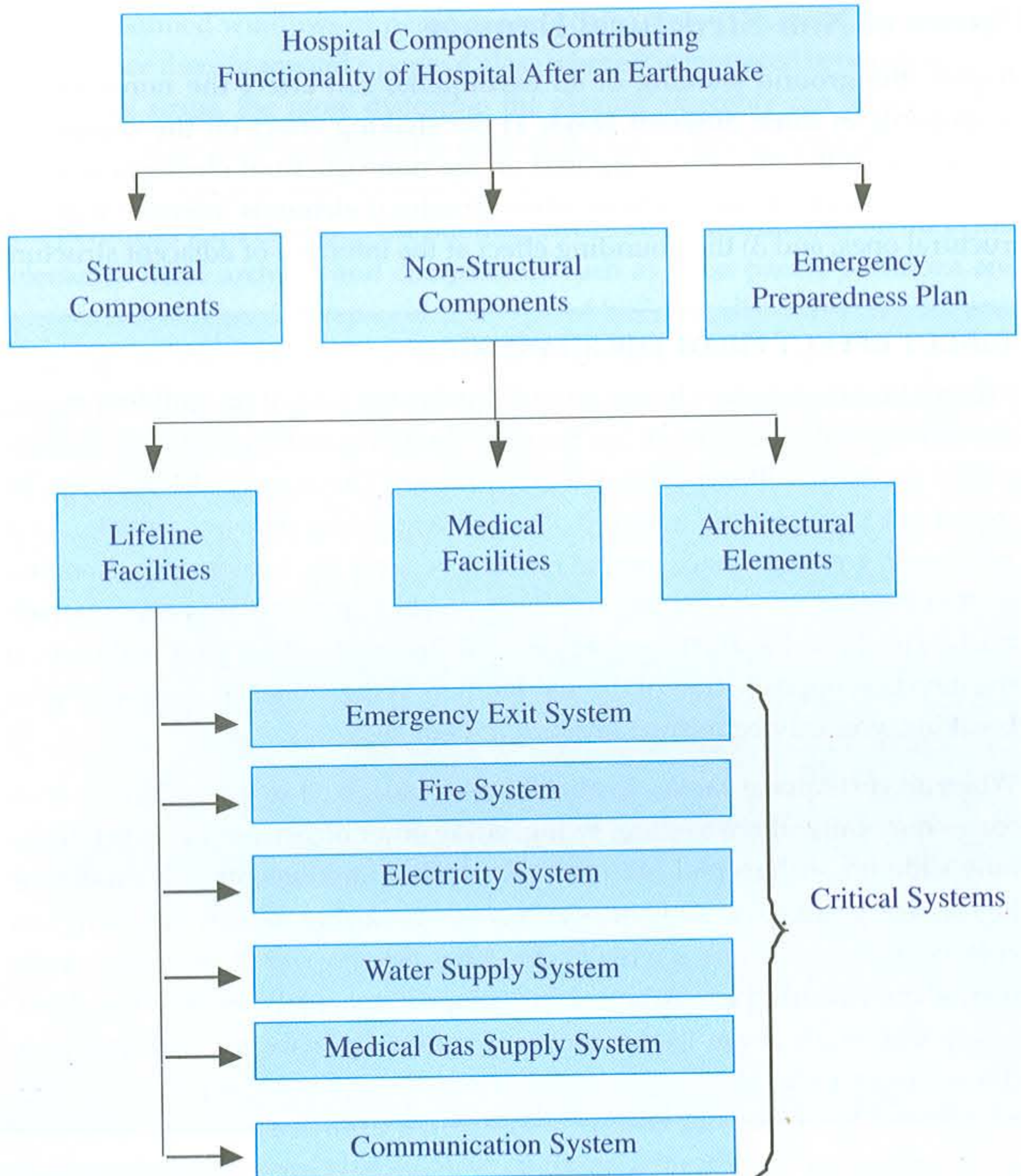

When assessing the overall vulnerability to earthquakes, all these components should ideally be taken into consideration. However, with regard to the everyday maintenance work being carried out in the health facility some general vulnerability patterns often exist, and a range of mitigation measures can be implemented that will help reduce the vulnerability of the non-structural components. Some of these possible mitigation measures are given in the next chapter, but first it is necessary to understand a bit about the different types and causes of damage to non-structural components during an earthquake as that will make it easier to understand what can be done to improve the safety.

Causes of Non-Structural Damage

Overall, the ground shaking of an earthquake can affect the non-structural components in three different ways; 1) the shaking effect on the components themselves, 2) the distortion imposed on the non-structural elements when the building sways back and forth or when structural elements interfere with non-structural ones, and 3) the pounding effect at the interface of adjacent structures.

DIRECT EFFECT FROM THE SHAKING:

When a building shakes during an earthquake, the base of the building moves in harmony with the ground, but the entire building and the building contents above the base will experience inertial forces. These inertial forces can be explained by using the analogy of a passenger in a moving vehicle. As a passenger, you experience inertial forces whenever the vehicle is accelerating or decelerating rapidly. If the vehicle is accelerating, you may feel yourself pushed backward against the seat since the inertial force on your body acts in the direction opposite that of the acceleration. If the vehicle is decelerating or breaking, you may be thrown forward in your seat.

When an earthquake shakes items which are not fixed to their place, inertial forces may cause them to slide, swing, strike other objects, or overturn. Items may slide off shelves and fall to the floor. One misconception is that large, heavy objects are stable and not as vulnerable to earthquake damage as lighter objects, perhaps because we may have difficulty moving them. In fact, since inertial forces during an earthquake are proportional to the mass of the object, heavy objects are more likely to overturn than lighter ones with the same dimensions.

EFFECT OF STRUCTURAL TO NON-STRUCTURAL COMPONENTS

During an earthquake, building structures distort, or bend, side to side in response to the earthquake forces. For example, the top of a tall building may incline a foot in each direction during an earthquake. The distortion over the height of each story, known as the story drift, might range from $\frac{1}{4}$ inches to several inches, depending on the size of the earthquake and the characteristics of the particular building structure. Windows, partitions and other items that are tightly locked into the structure are forced to move with it. As the columns or walls distort and become slightly out of square, if only for an instant, any tightly confined windows or partitions must also distort the same amount. The more space there is around a pane of glass where it is mounted between stops or moulding strips, the more distortion the glazing assembly can accommodate before the glass itself is subjected to earthquake forces. Brittle materials like glass, plaster and masonry infill cannot tolerate any distortion and will crack when the perimeter gaps close and the building structure pushes directly on the brittle elements. Most architectural components such as glass panes, partitions and veneer are damaged because of this type of building distortion, not because they themselves are shaken or damaged by inertial forces.

POUNDING EFFECTS:

Another source of non-structural damage involves pounding or movement across separation joints between adjacent structures. A separation joint is the distance between two different building structures - often two wings of the same facility - that allows the structures to move independently of one another. A seismic gap is a separation joint provided to accommodate relative lateral movement during an earthquake. In order to provide functional continuity between separate wings, building utilities must often extend across these building separations, and architectural finishes must be detailed to terminate on either side. The separation joint may be only an inch or two in older constructions or as much as a foot in some newer buildings, depending on the expected horizontal movement. Flashing, piping, fire sprinkler lines, HVAC ducts, partitions, and flooring all have to be detailed to accommodate the seismic movement expected at these locations when the two structures move closer together or further apart. Damage to items crossing seismic gaps is a common type of earthquake damage. If the size of the gap is insufficient, pounding between adjacent structures may result in damage to structural components such as parapets, veneer, or cornices on the facades of older buildings.

3. Non-Structural Vulnerability Mitigation Measures

The following suggestions for mitigation measures are all based on components typically found in hospitals or health facilities. These general measures are applicable to almost all situations. However, it is important to remember that they are general suggestions, and that other solutions may be better in individual cases. In many cases, it is enough to be creative and to devise one's own way of mitigating the effects of disasters. The suggested mitigation measures are listed alphabetically.

Anchorage

The heavier the object, the more likely it is that it will move due to the forces produced by an earthquake. By using bolts, cables or other materials to prevent valuable or large components from falling or sliding, they are much more likely to be functional after an earthquake. Autoclave machines are a good example. They are heavy and can easily fall and break. The simple solution is to anchor the feet of the machine to the concrete floor.



Anchorage 1:6
Autoclave machine without anchorage.

Anchorage 2:6

This machine can be fixed to the floor by casting a concrete base.

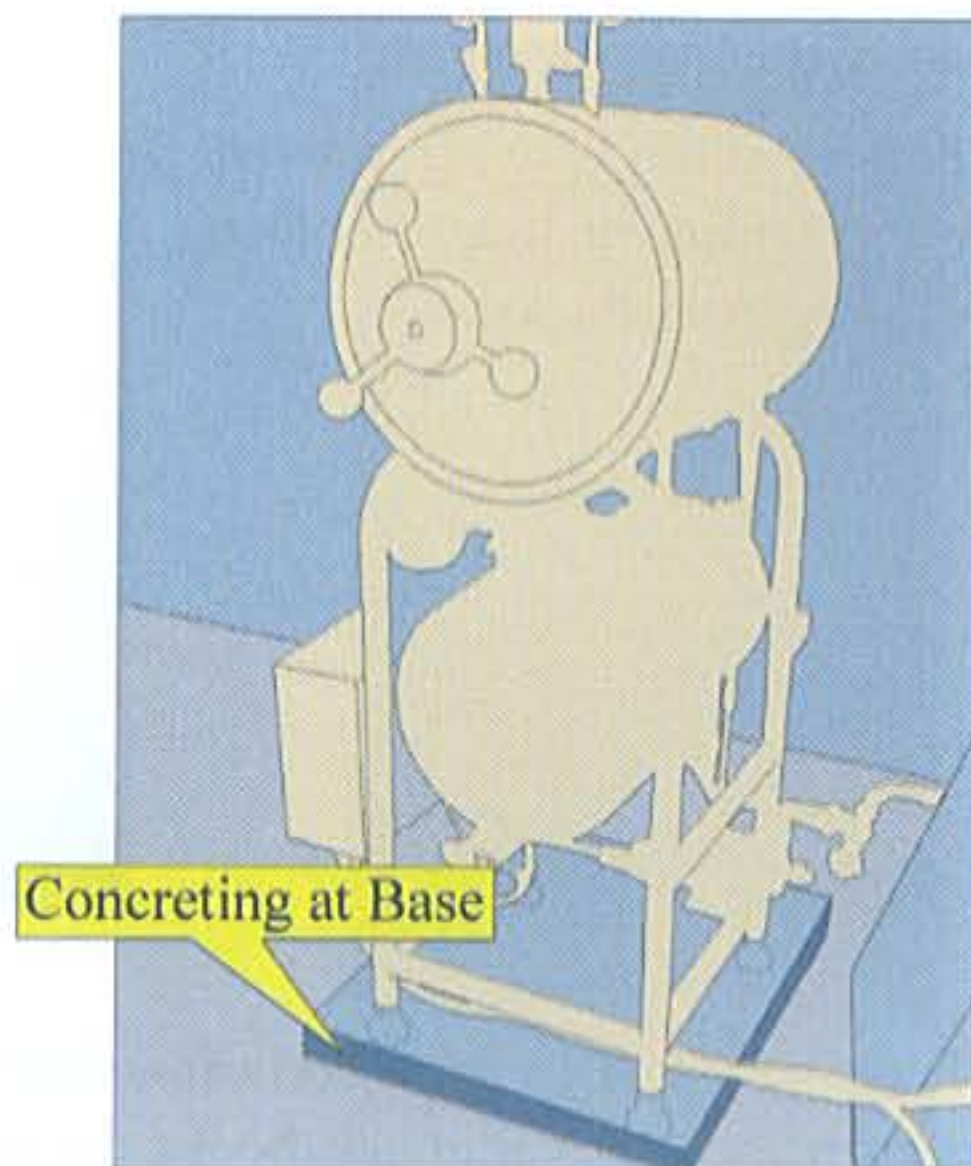

Also other types of equipment and components of a system can easily be bolted to the floor. Typical examples are transformers, water treatment tanks, communication equipment and control panels of X-ray machines.

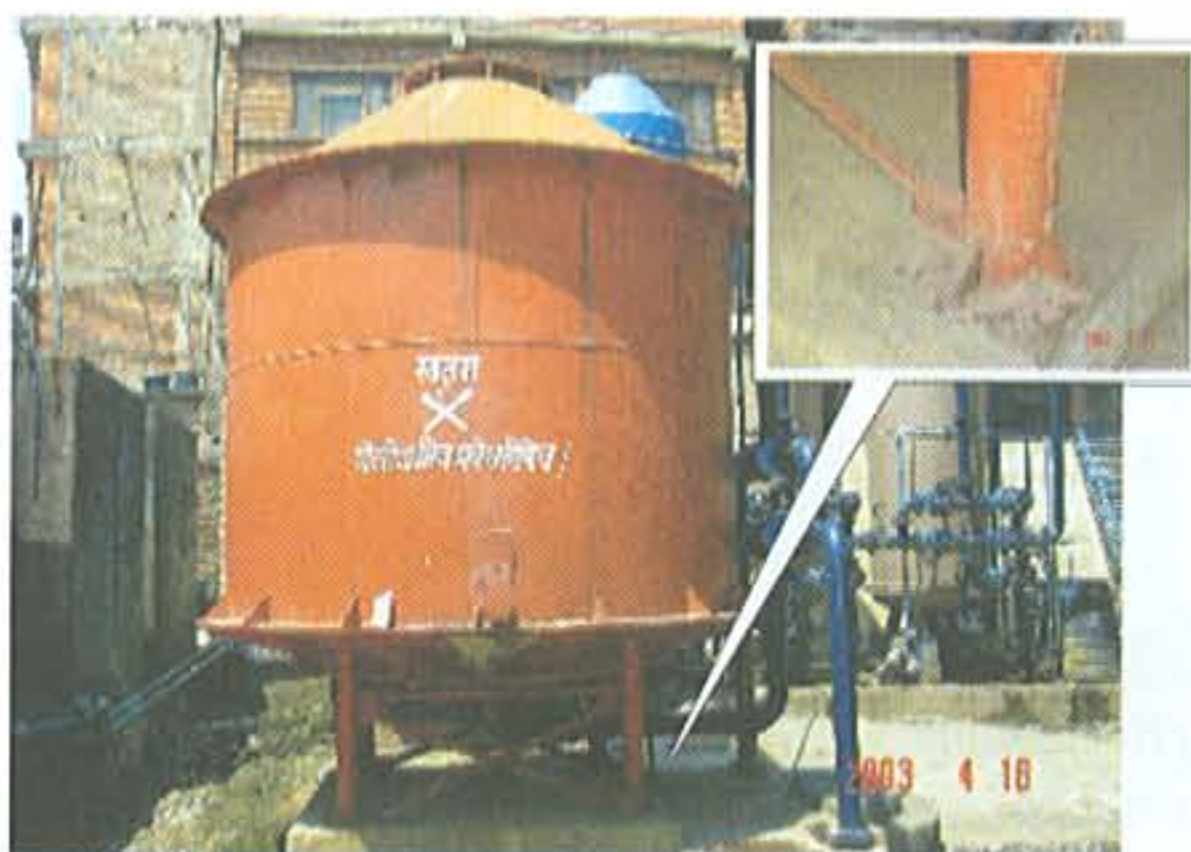

Anchorage 3:6

Water treatment tank which has a provision for bolting at the base but is not bolted.

Anchorage 4:6

Bolting at the base can prevent overturning of heavy objects during an earthquake.

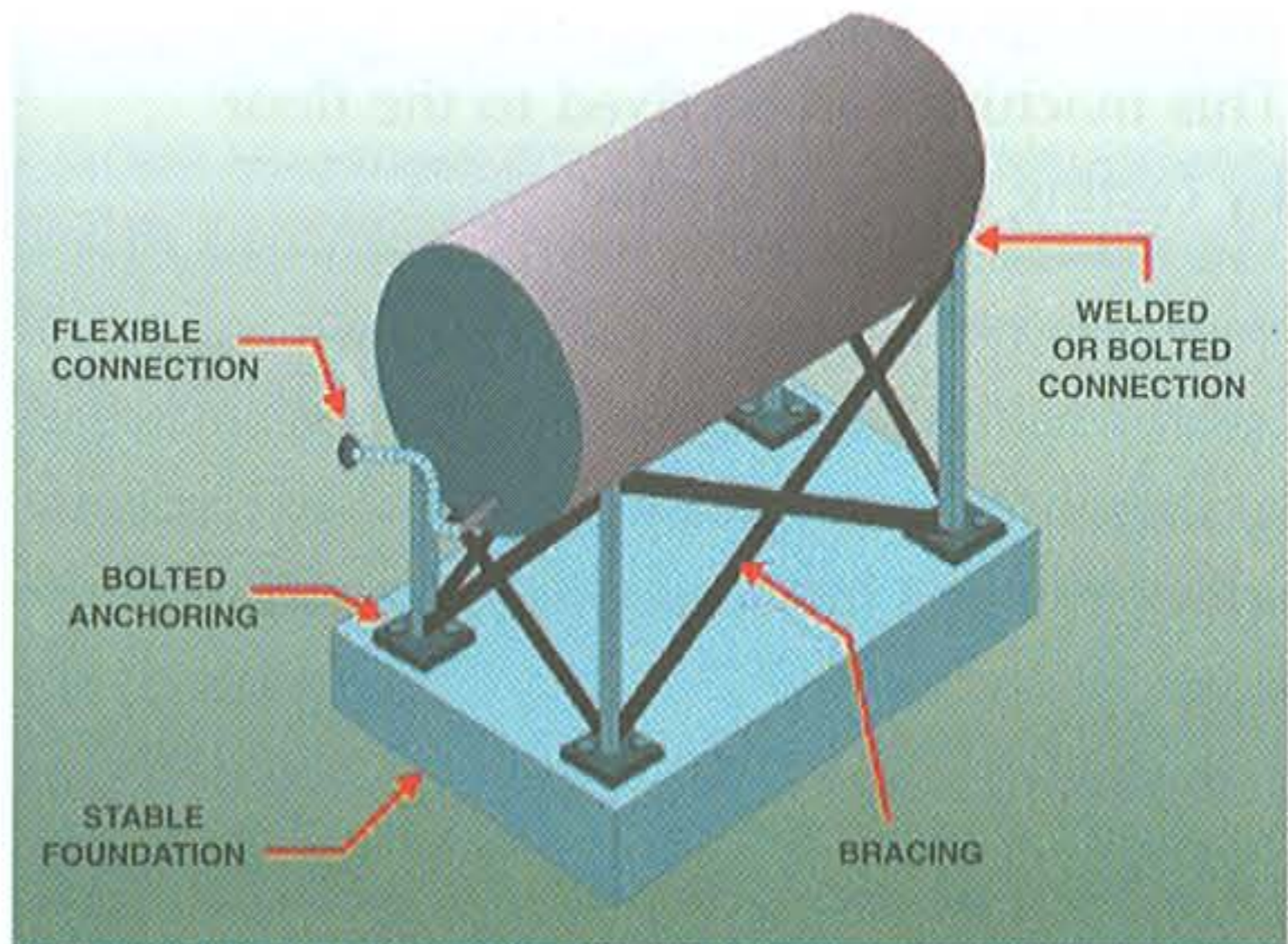

In most medical facilities and administration sections, cupboards, fridges and racks storing medical equipment, books, documents or chemicals pose life safety hazards as well as functional and / or property losses. This can easily be prevented by anchoring them to the wall using angles and nails as this will stop them from overturning.



Anchorage 5:6

Tall and narrow objects like fridges can easily overturn during earthquakes.

Anchorage 6:6

Such objects can be protected from overturning by bolting them to the wall

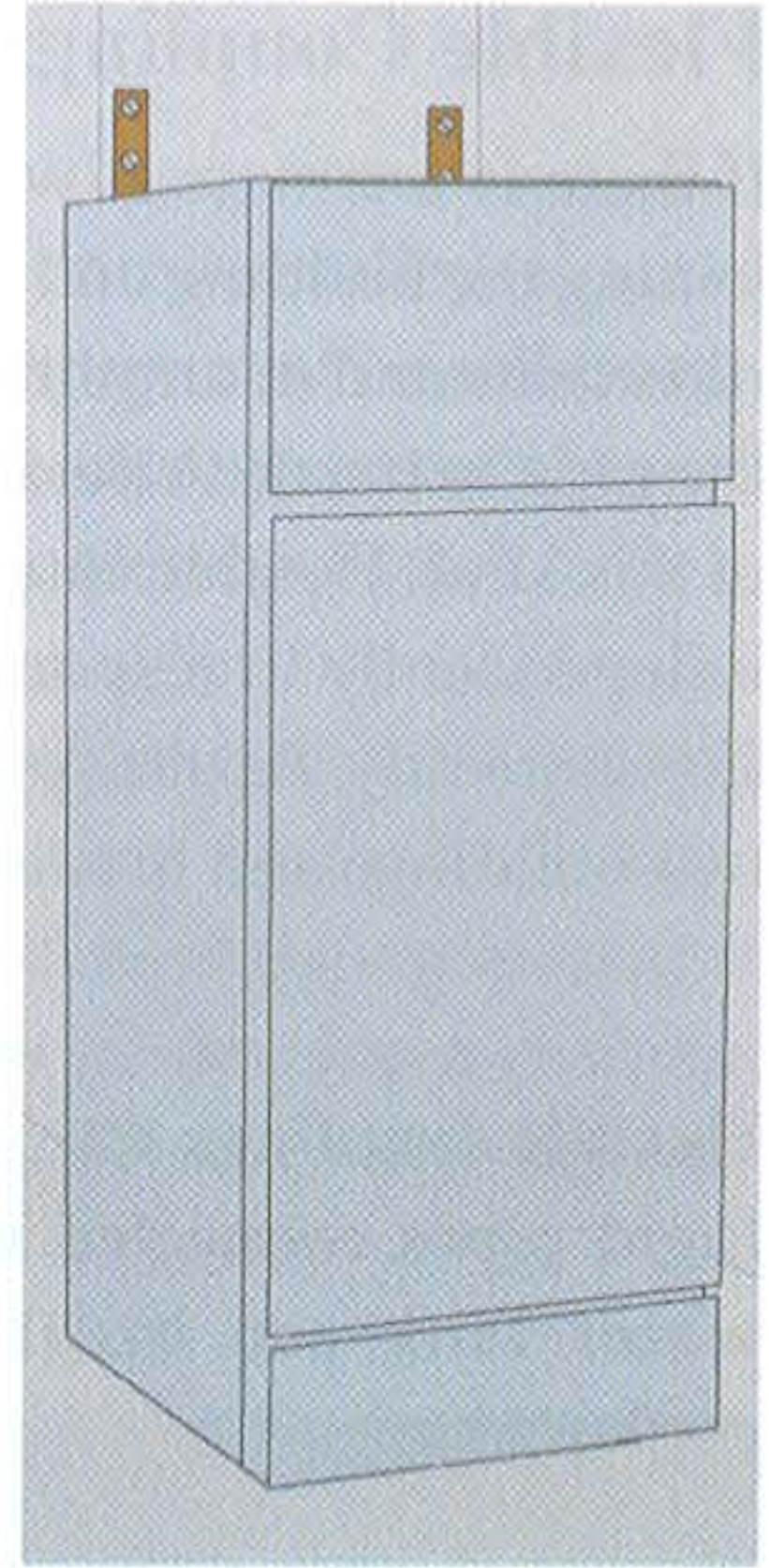

Chaining System on Beds

In important wards like ICU, CCU, post operative, and maternity wards the equipment and the accessories needed for the treatment are generally placed near to the beds but without any anchor or support. This equipment and accessories should be fixed to reduce the vulnerability and enhance the hospital performance after an earthquake. Providing chains and anchor hooks on each bed could solve the problem.

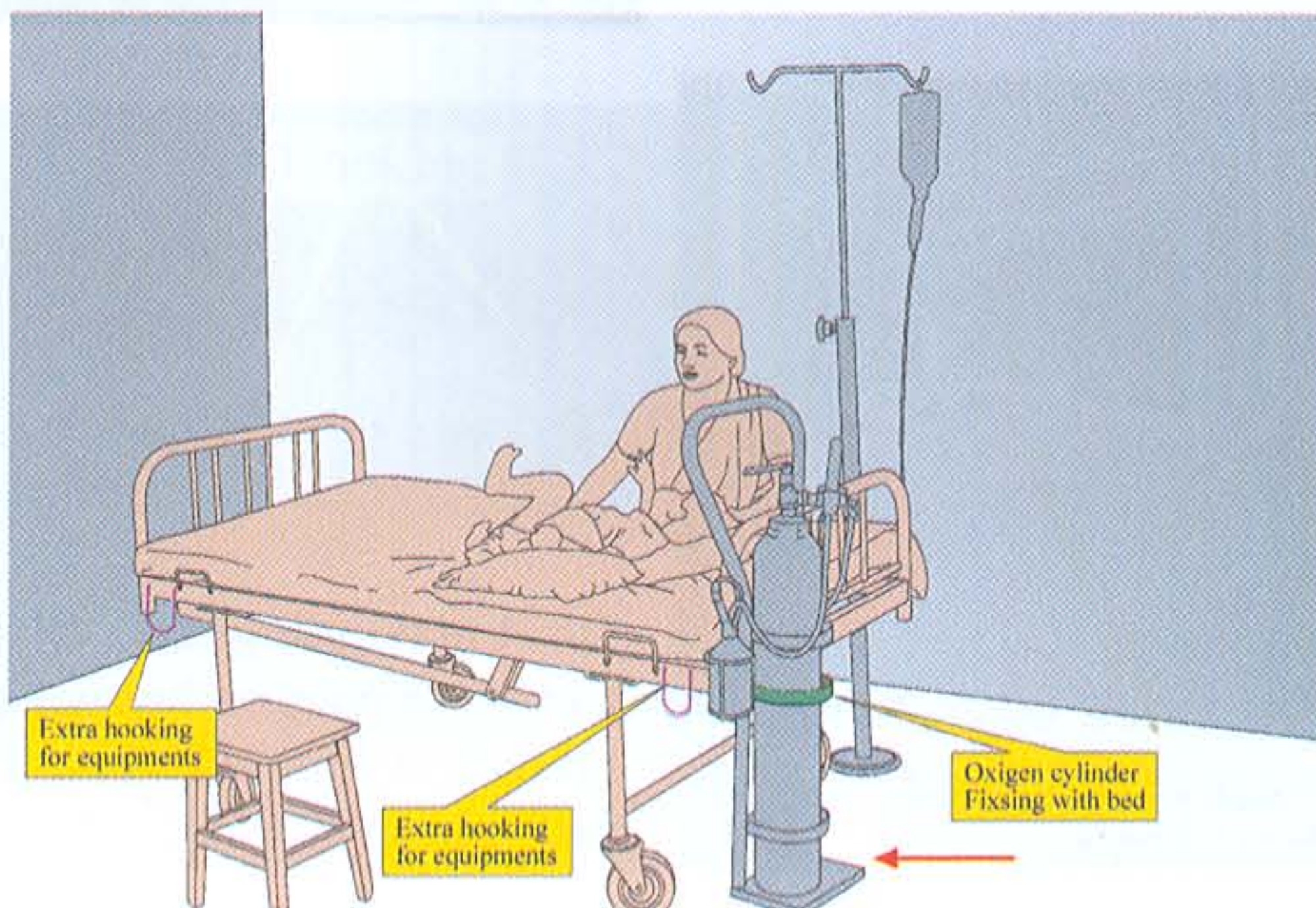

Flexible Couplings

If there is a tank (e.g. water) outside the building with a rigid connection pipe joining the building and the tank together, the tank will vibrate at frequencies, in directions and at amplitudes different to those of the building, which will cause the pipe to break. A flexible pipe between the two parts would prevent ruptures of this kind. Flexible couplings are necessary because separate objects each move independently in response to an earthquake; some move quickly, others slowly. Consequently, flexible piping is necessary near heavy equipment, at the joint of two buildings and in seismic joints of the same building.

Flexible couplings 1:2

Rigid pipes connected with a heavy water tank can break during an earthquake.

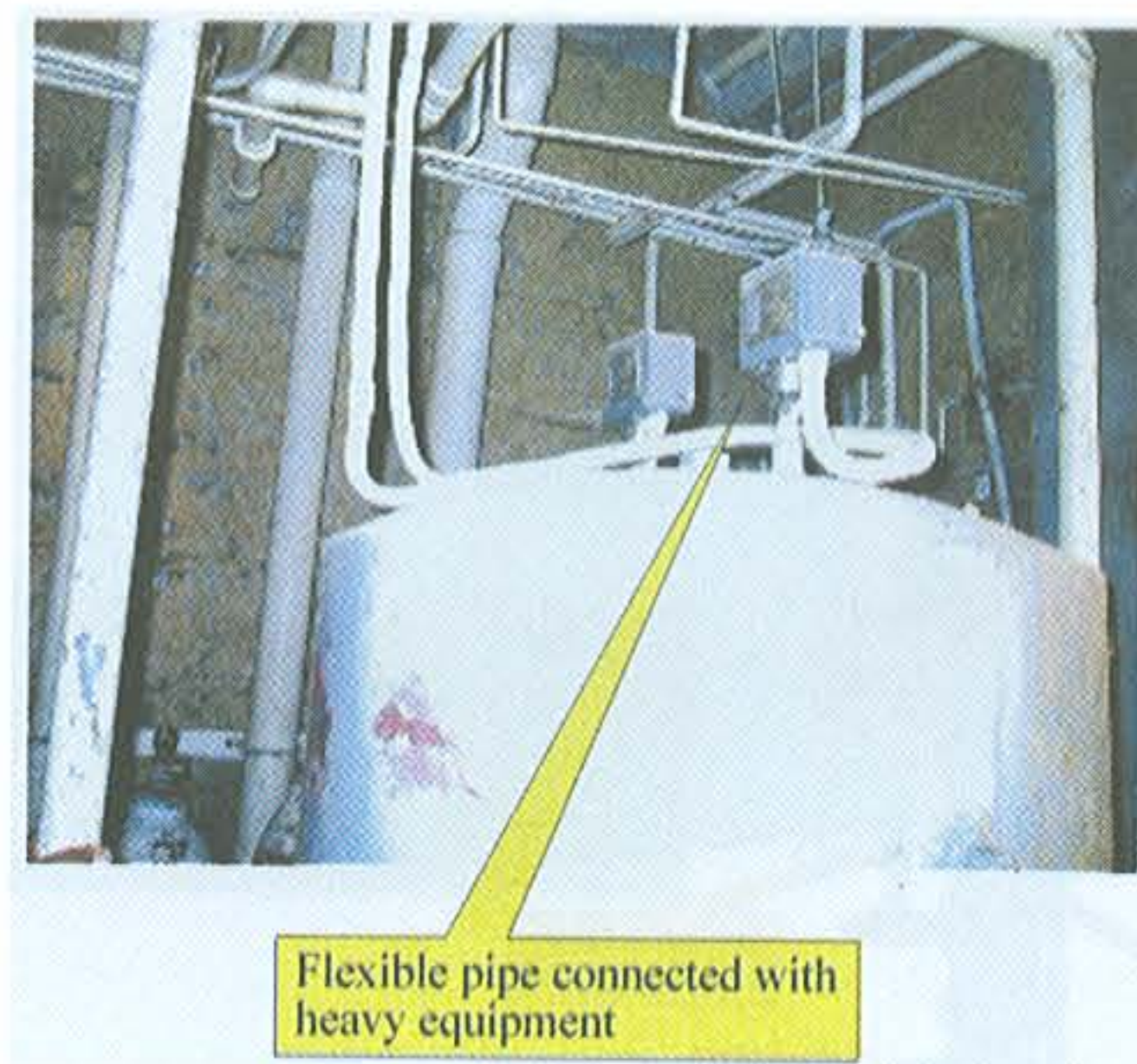
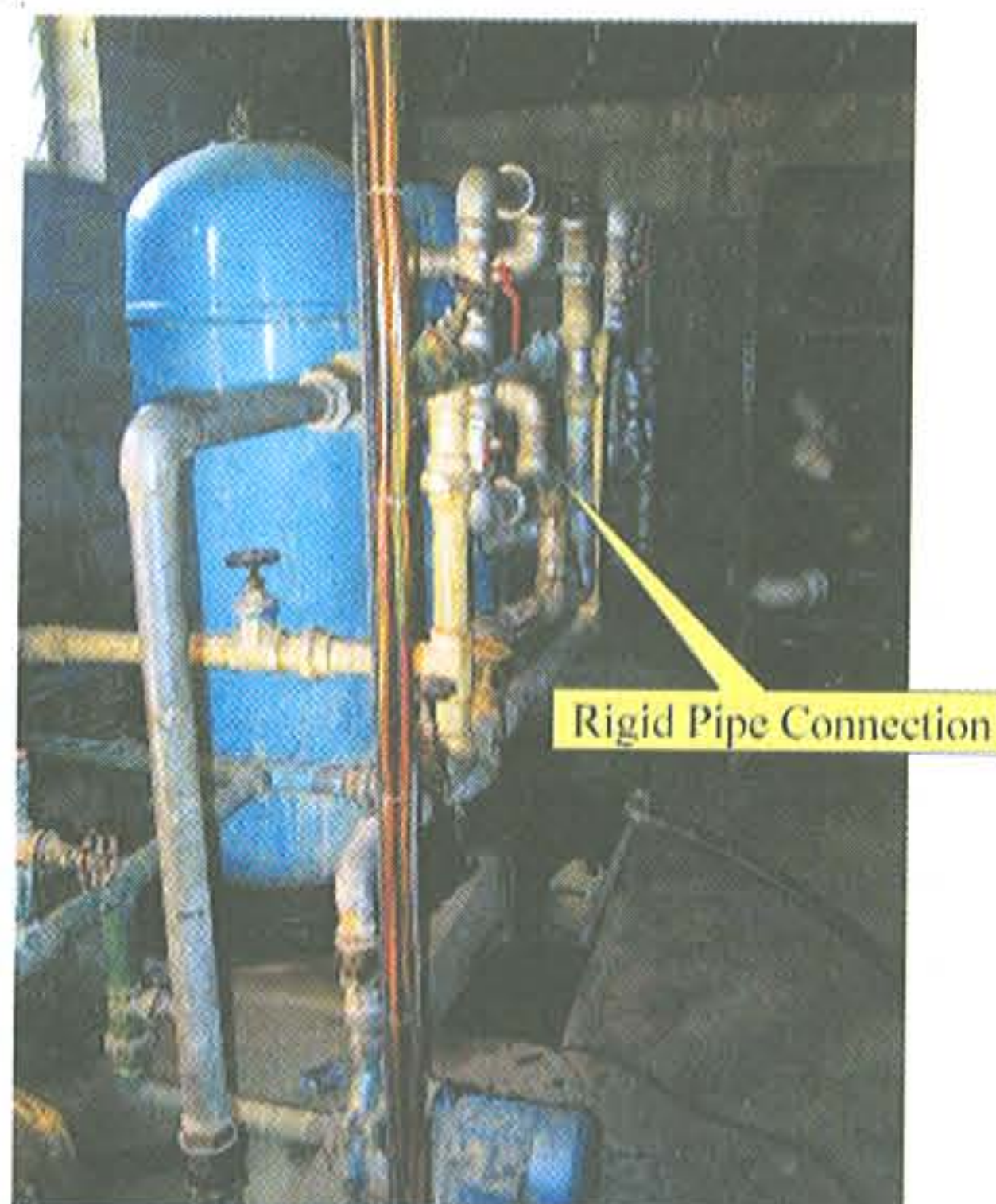

Flexible couplings 2:2

Flexible piping on heavy equipment protects it from breaking during an earthquake.

Hooking

Much equipment like ECG monitors, suction units, ventilators, incubators, B.P. monitors, resuscitation equipment, etc. are kept on rollers or roller trolleys to make them more mobile and easy to use. The problem is that equipment on rollers can slide and impact with people, walls, beds or other things causing impact hazard to the other object or person and damage to the piece of equipment itself.

Development of a proper hooking system using chains and hooks can protect this equipment and can decrease the impact hazard at the time of use or storage. Provision of a hooking system on beds could be one way of hooking equipment at the time of use (see p. 12 for further elaboration of how to develop a chaining system for beds). At the time of storage, the equipment can be hooked to the wall by chains.

Hooking 1:8

ECG monitors on rollers with potential risk of sliding and overturning.

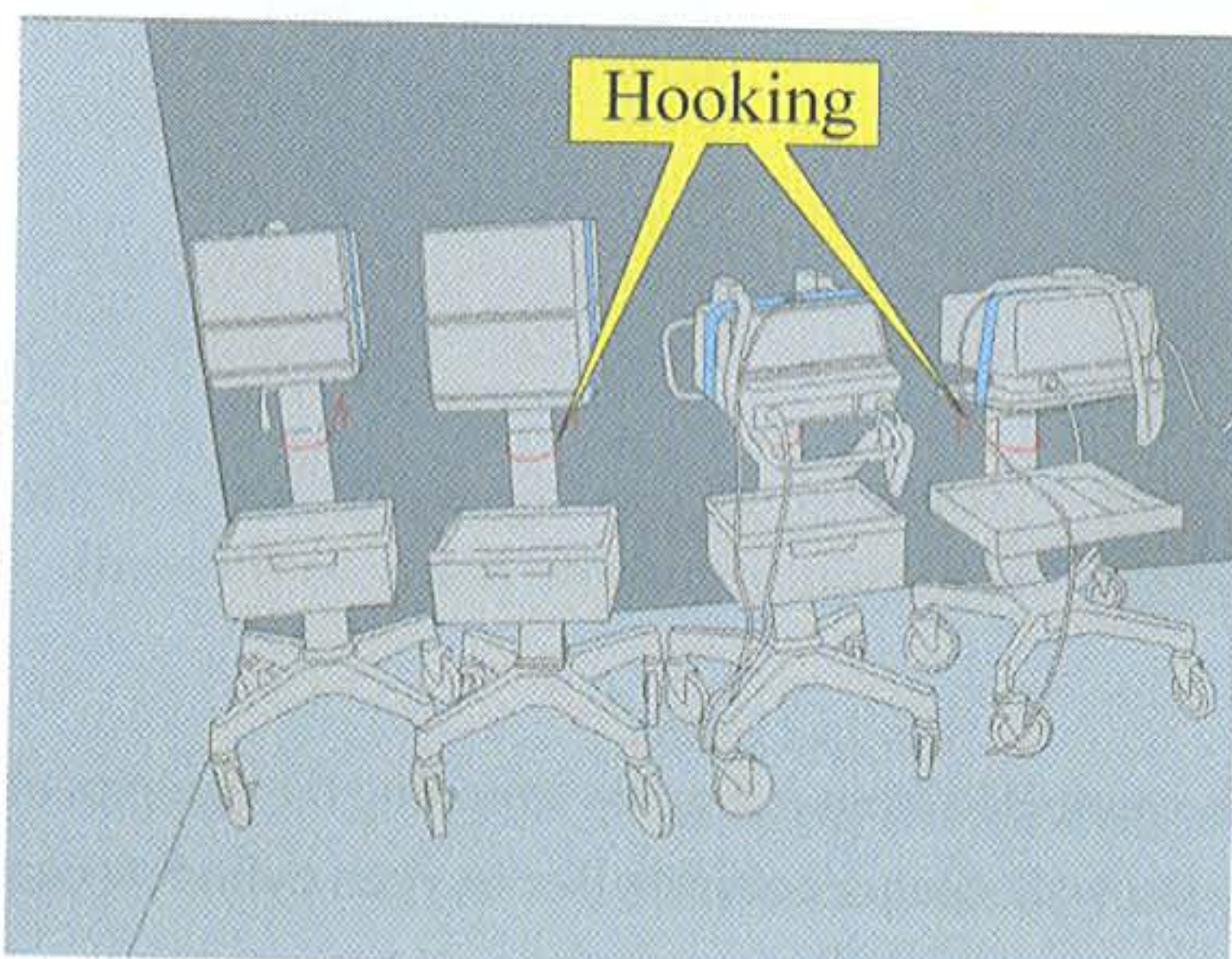

Hooking 2:8

Provision of chains on the wall to hook such machines

Hooking 3:8
Mobile X-ray on rollers.

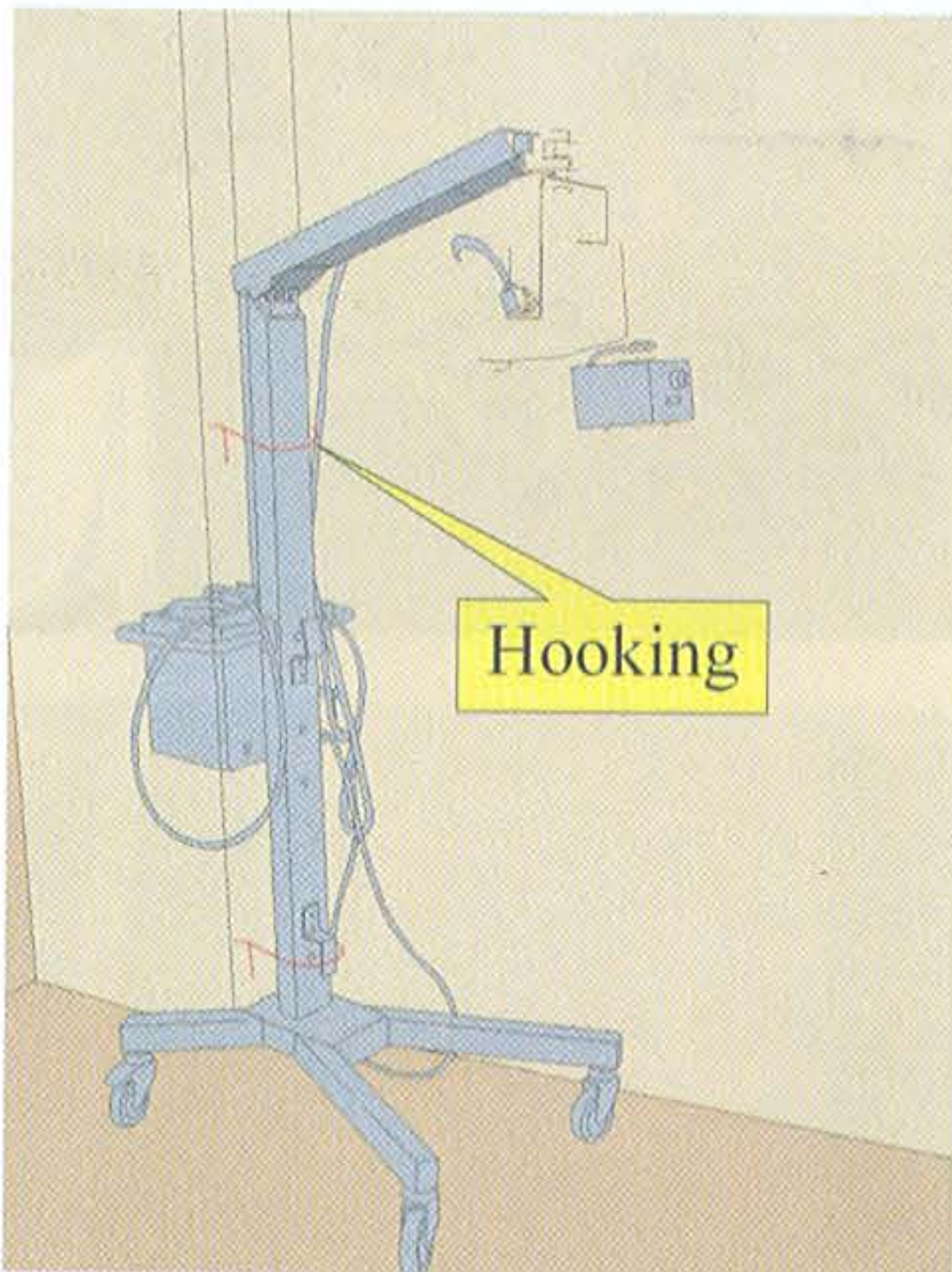
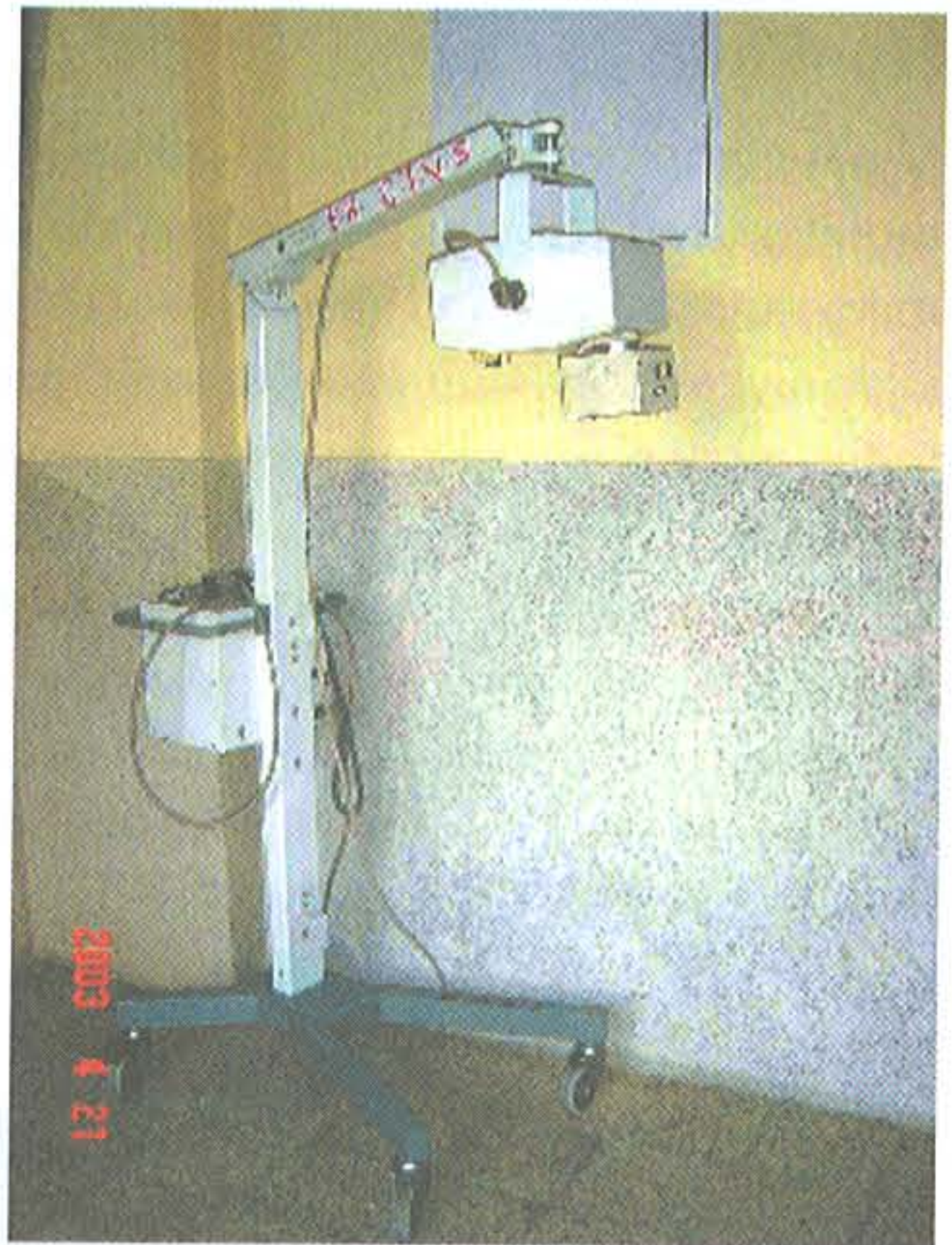

Hooking 4:8
Hooking of mobile X-ray to the wall.

Some equipment on roller trolleys can be protected from falling by strapping the equipment to the trolley and hooking the trolley to the wall. Slender objects like oxygen cylinders can be hooked using chains.



Hooking 5:8
Resuscitation equipment on roller trolleys.

Hooking 6:8
Hooking of the trolley and strapping of the equipment.

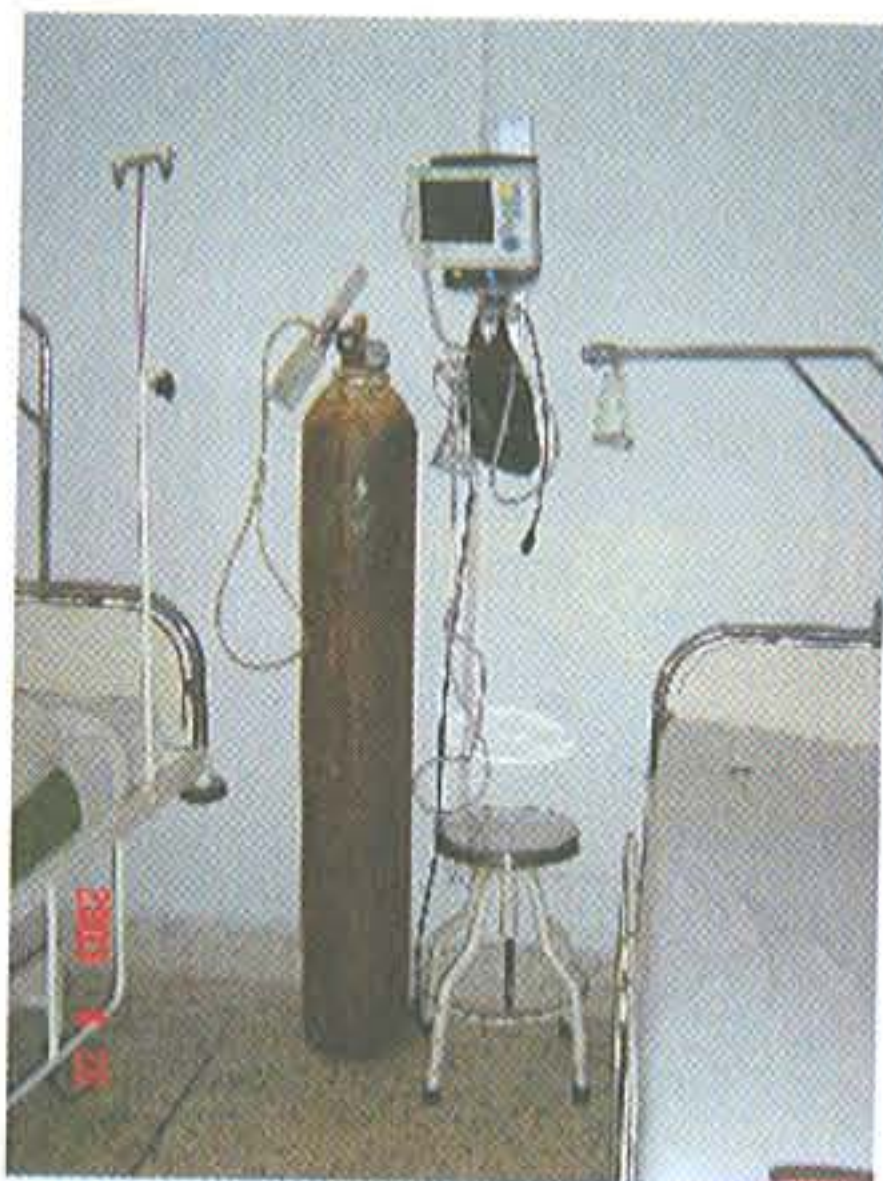
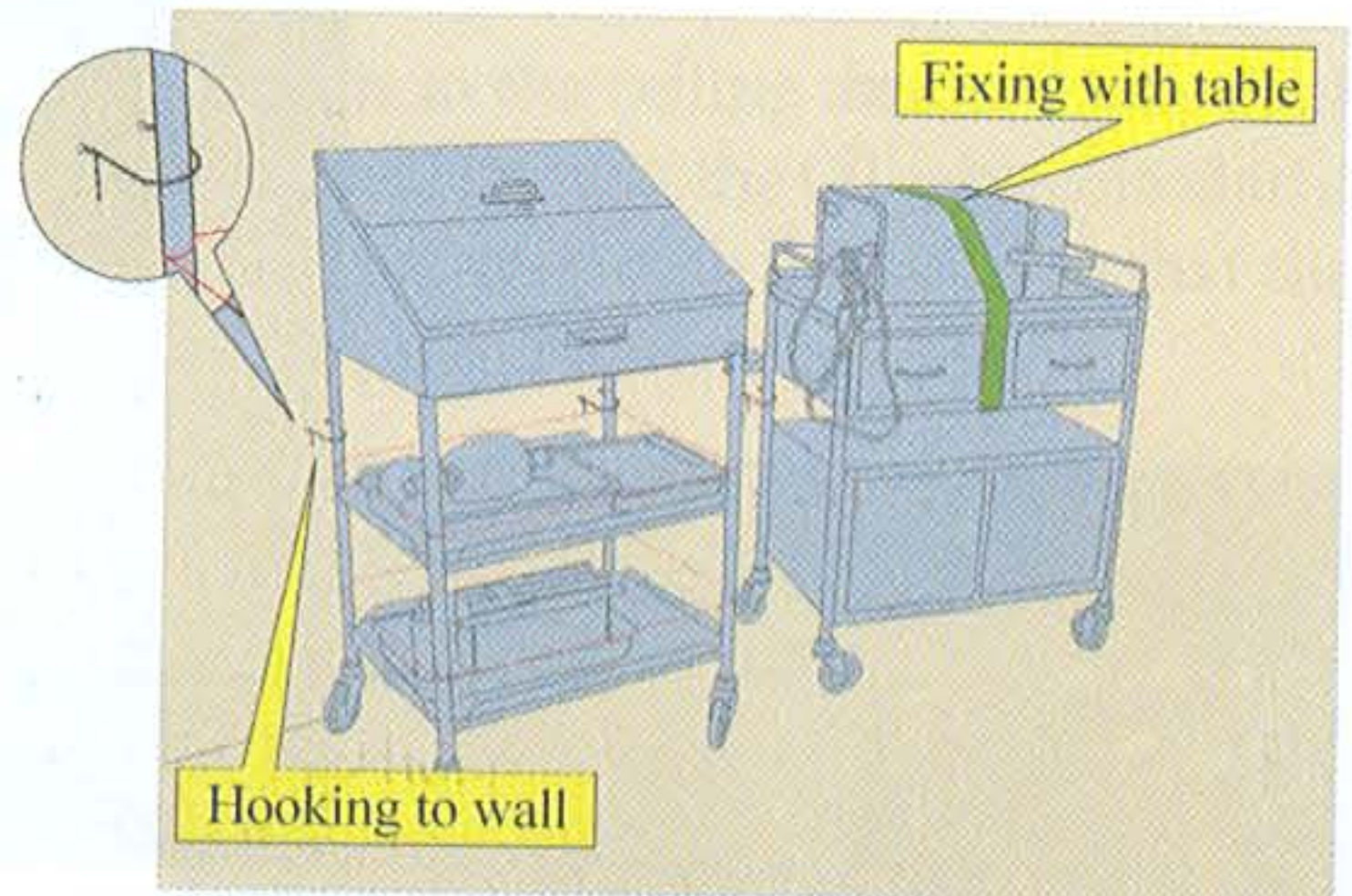

Hooking 7:8
Un-hooked oxygen cylinders may fall over.

Hooking 8:8
Hooking the cylinder with a chain can save the cylinder from falling.



Modification

Modification is a possible solution for an object that represents a seismic hazard. For example, earth movements twist and distort a building possibly causing the rigid glass in the windows to shatter and launch sharp glass splinters onto people. Rolls of transparent adhesive plastic may be used to cover the inside surfaces and prevent them from shattering and threatening those inside. The plastic is invisible and reduces the likelihood of a glass window causing injuries.

Modification 1:2

This window glass can cause a life safety hazard.



Modification 2:2

Simple plastic lamination can protect lives

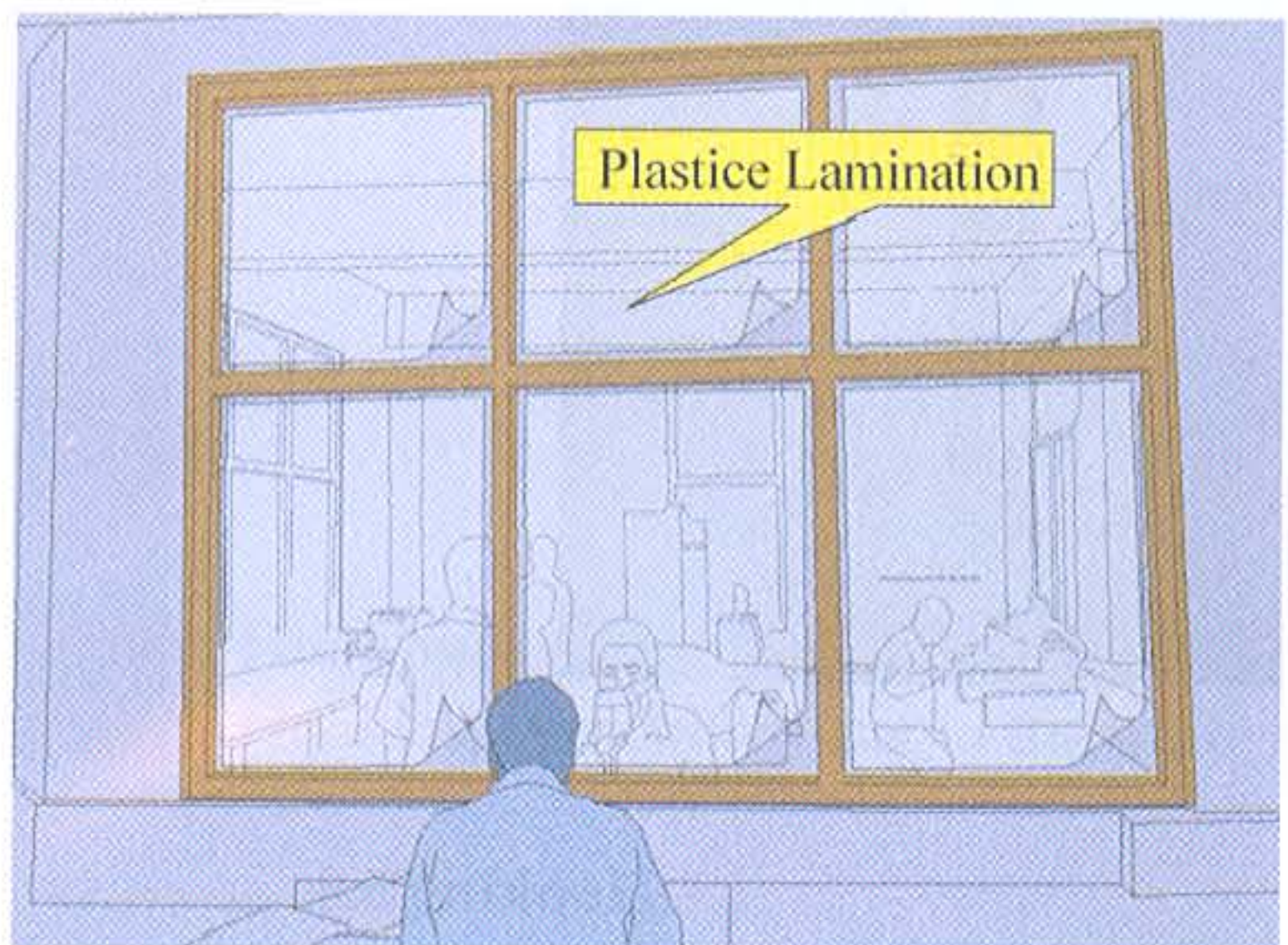

Operation Theatres

In most Nepalese hospitals, almost all equipment in the operation theatres is mounted on rollers or roller trolleys. If there are no provisions for fixing them they are highly vulnerable. However, for everyday use this equipment must be flexible and mobile and cannot be permanently fixed. Thus a special system for anchoring the equipment is necessary; anchoring which can fix the equipment during operations and can be removed afterwards.

The system can be a steel frame consisting of vertical and horizontal angles attached to the equipment rack. The system should have a number of chains, straps, hooks and guide bars in the rack for fixing and securely placing the equipment in the rack. The frame can then be fastened in a location near to the operation table during the operation. By providing anchor bolts in the ceiling and in the floor of the room the equipment rack can be placed in position near the OT table. Similarly, anchor bolts should be provided in the walls in appropriate locations so that the equipment can be removed and fixed in a safe place when not used.

OT 1:2

Most equipment is on roller trolleys (equipment racks) in operation theatres. The risk of falling down is high.

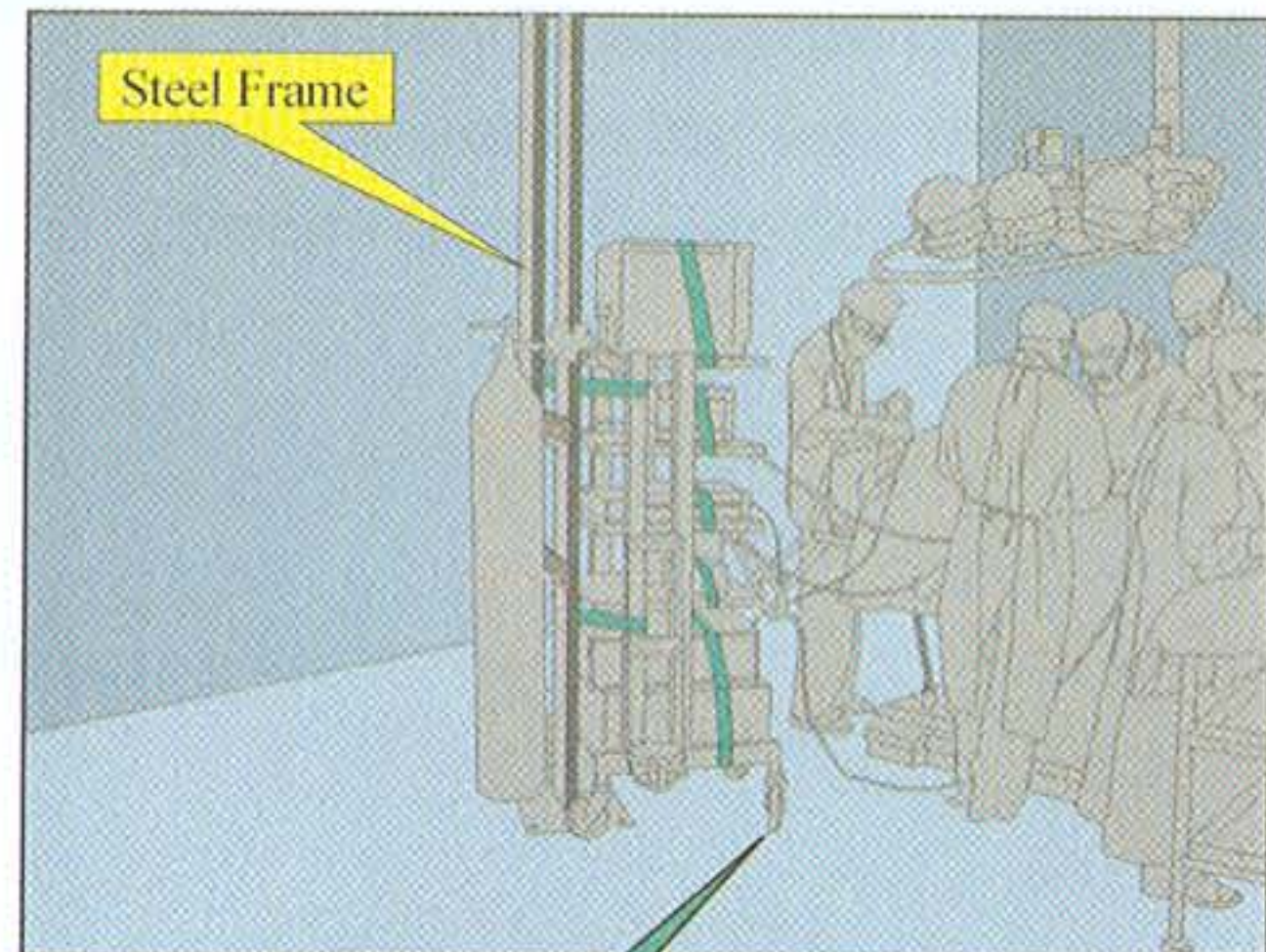

OT 2:2

Tying all equipment to a steel frame can improve the situation.



Rapid Response and Repair

Sometimes it is not possible to do anything to prevent the rupture of a pipeline in a given place. Instead, spare parts can be stored nearby and arrangements made to enter the area quickly in case a pipe breaks during an earthquake. A hospital should have spare plumbing, emergency power supplies and other necessary components on hand together with the suitable tools in order to ensure that repairs can be easily made if something is damaged. For example, during an earthquake the water pipes may break. It may be impossible to take prior measures to totally eliminate this risk, but it is possible to ensure that everything necessary for quick repairs is at hand. With prior earthquake planning it is possible to save the enormous costs of water damage with a minimum investment in a few articles.

Redundancy

Redundancy or duplication of items is advisable. Emergency response plans that call for additional supplies are a good idea. It is possible to store extra amounts of certain products (such as fuel for generators) as this will provide a certain level of independence from external supplies, which could be interrupted in case of an earthquake.

Reinforcement

Reinforcement is feasible in many cases. For example, an un-reinforced infill wall or a chimney may be strengthened without great expense by covering the surface with wire mesh and cementing it.

Removal & Relocation

Removal is probably the best mitigation option in many cases. Unnecessary or non-essential documents and materials stored near the working place or near important equipment can often be removed and stored in another place where it does not pose a threat.

Removal & relocation 1:4

These document packs stored on the top of book shelves and cupboards are a life safety hazard.

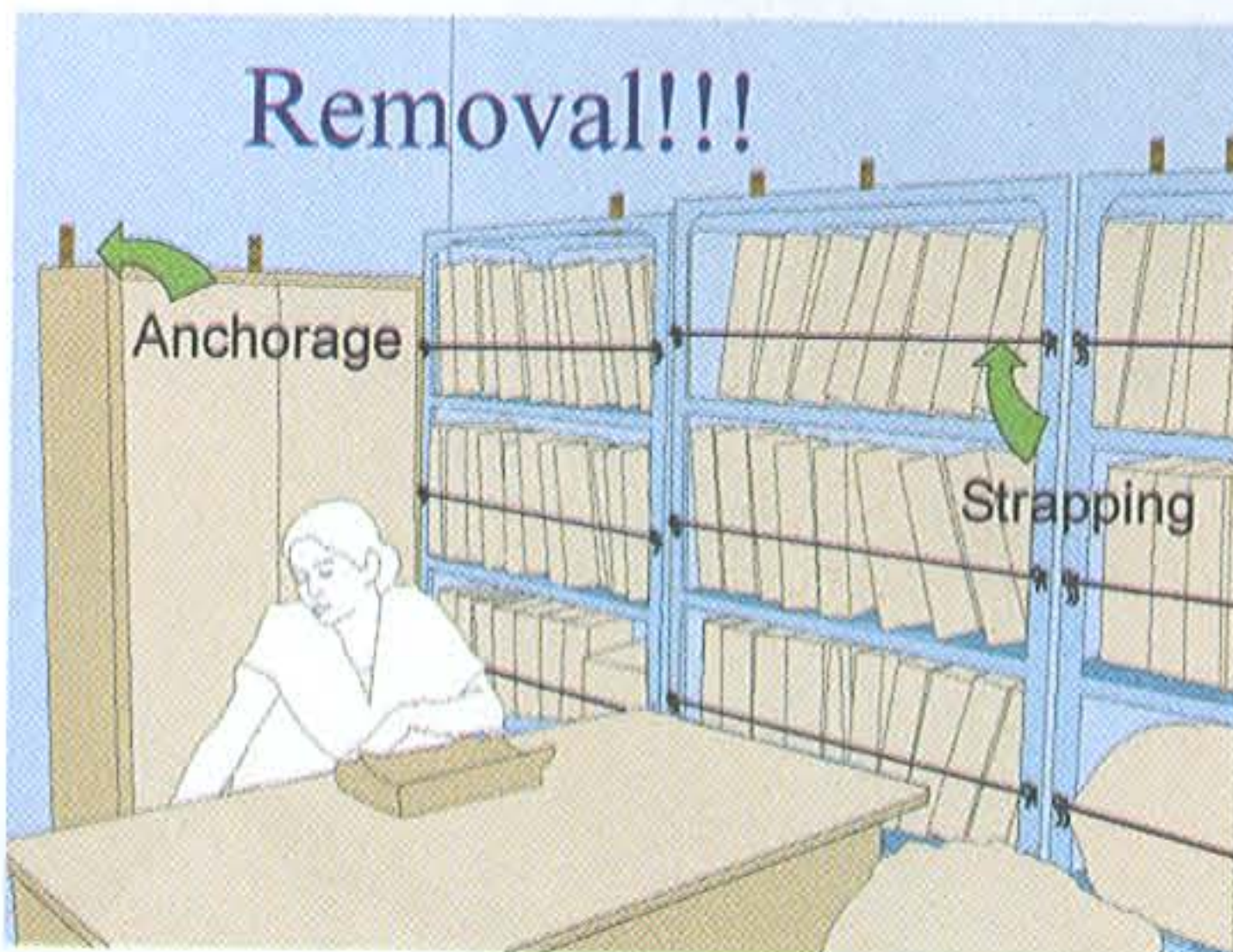
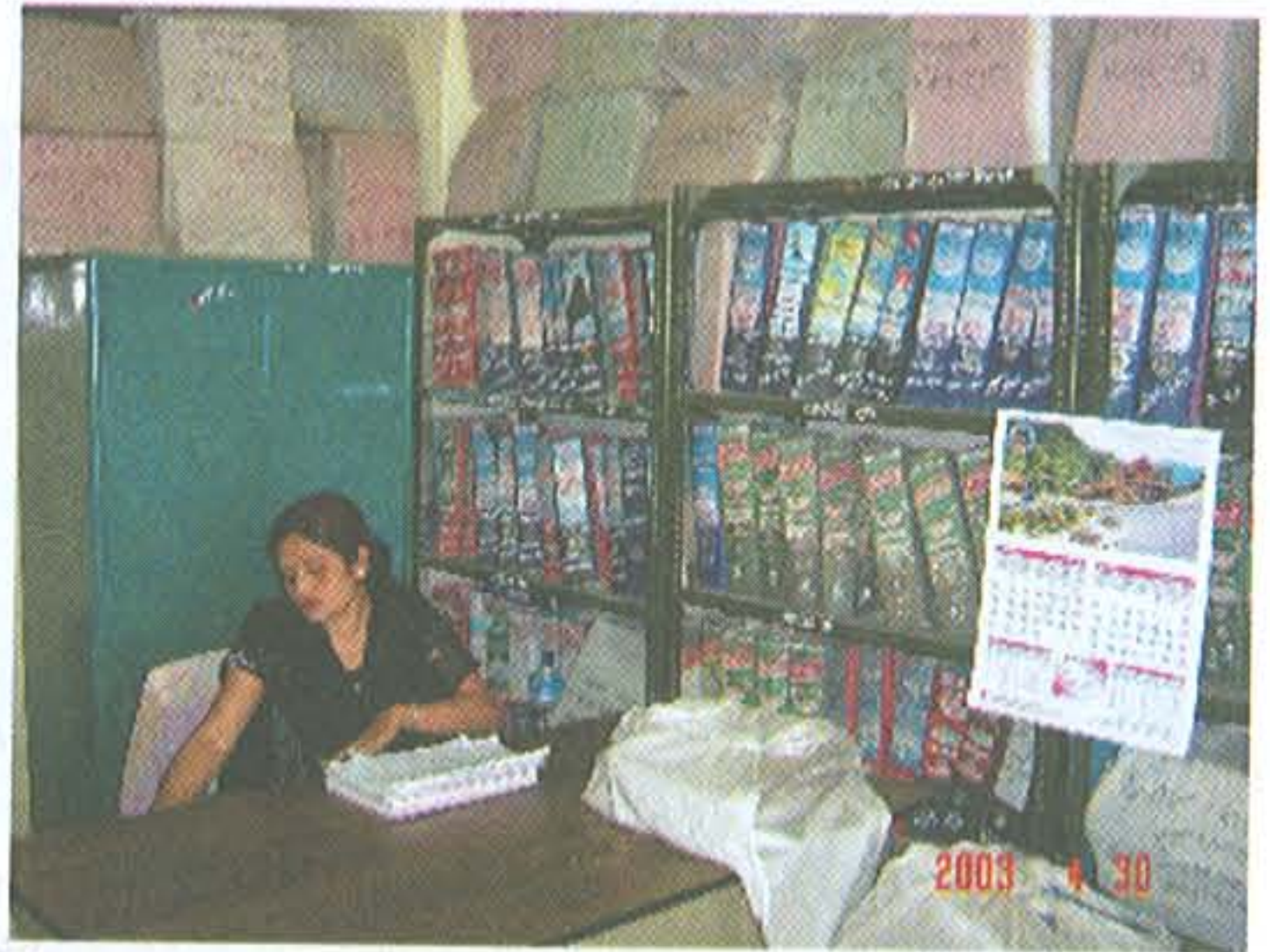

Removal & relocation 2:4

Life safety hazards can be reduced just by removing less important things from the working place.

Very heavy objects kept on top of a shelf could fall and seriously injure someone as well as break thereby causing economic losses. But by relocating heavy equipment and materials from upper shelves to lower shelves the risk could be mitigated. Other examples of risks that can be lessened by relocation of objects are cupboards and book shelves kept near exit doors or passages as they can obstruct the way and cause human death or injury during an earthquake event.

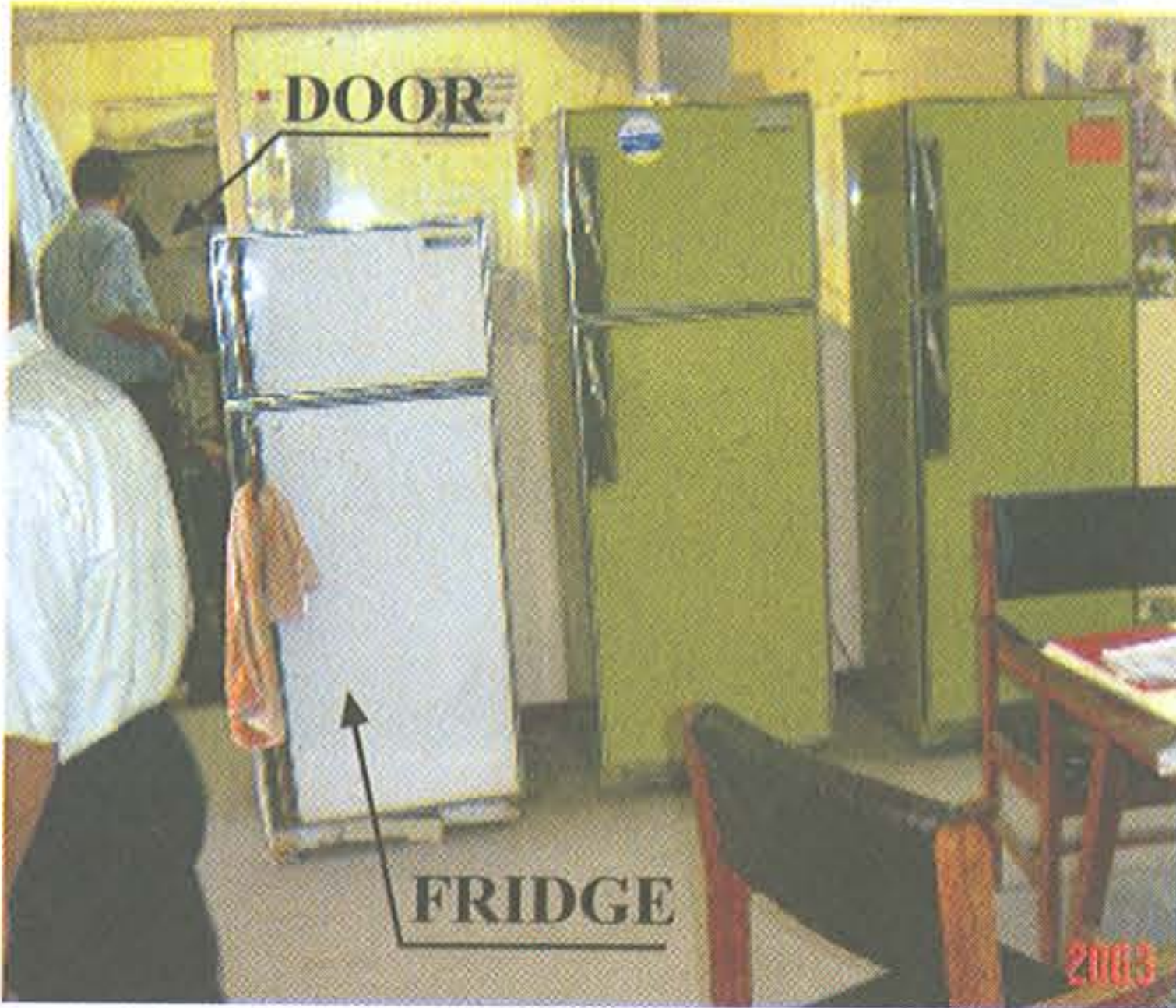

Removal & relocation 3:4
The fridge kept near an exit door is a life safety hazard.

Removal & relocation 4:4
These cupboards can block the corridor and are a life safety hazard.

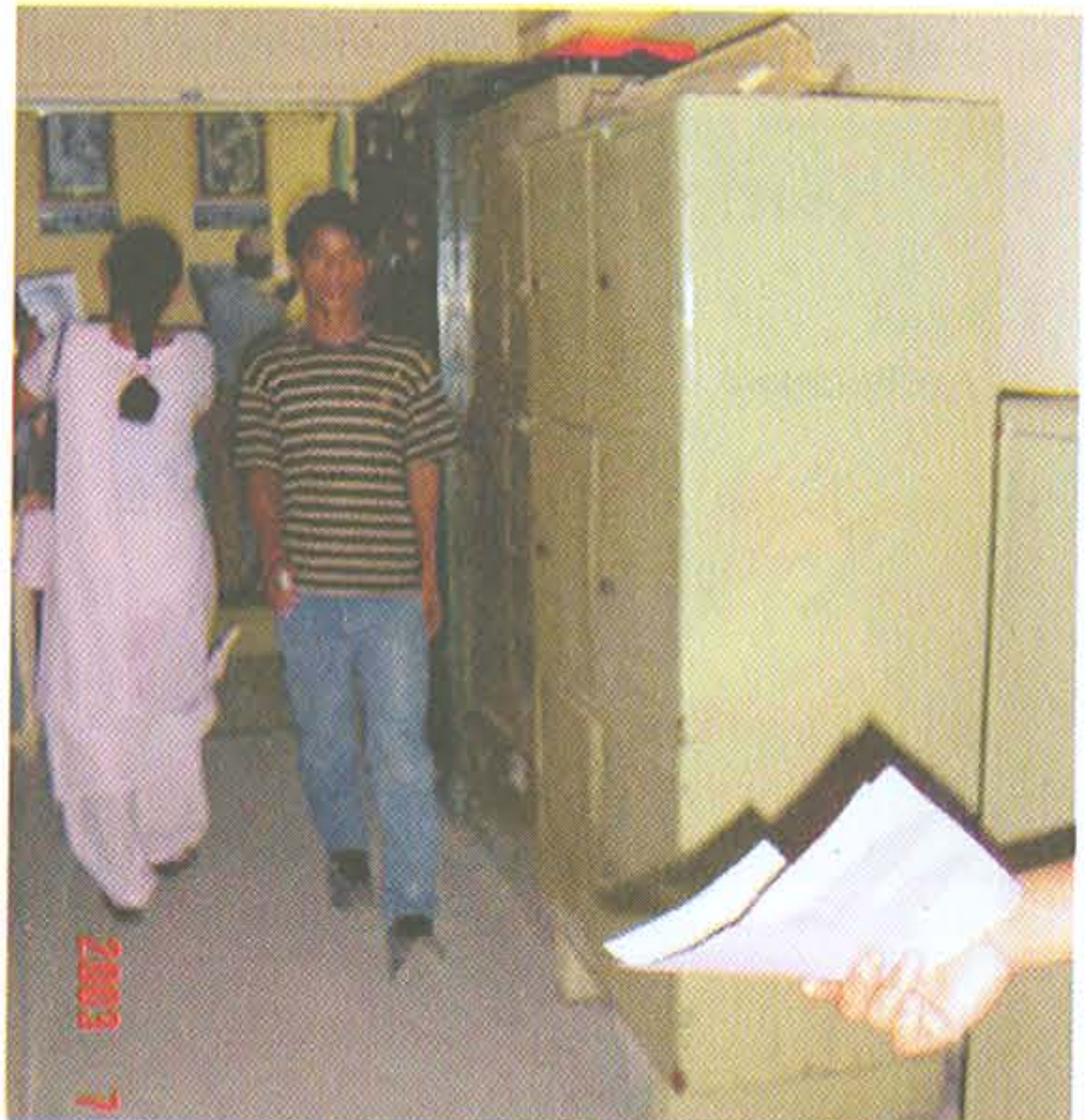

Restricted Mobility

For certain objects such as gas cylinders and power generators, restricted mobility is a good measure. It does not matter if the cylinders shift as long as they do not fall and break their valves. Sometimes back-up power generators are mounted on springs to reduce the noise and vibrations when they are working, but these springs would amplify ground motion. Therefore, restraining supports or chains should be placed around the springs to keep the generator from shifting or being knocked off its stand.

Restricted mobility 1:2

A generator on rollers can slide and overturn in an earthquake causing functional loss.

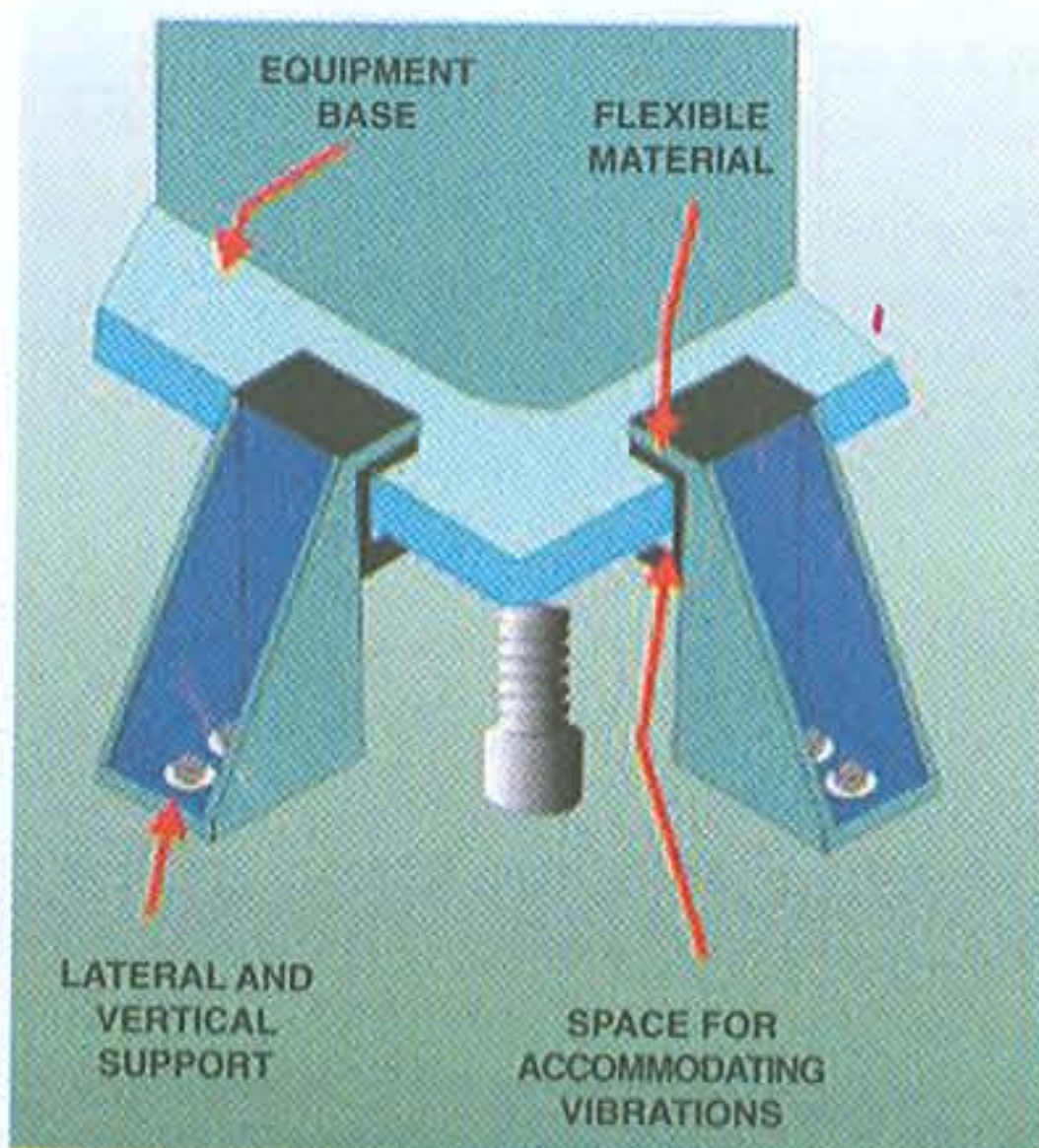

Restricted mobility 2:2

Generators and other vibrating equipment can be fixed by special brackets, which allow some movement but prevent them from overturning.

Strapping

Supplies and contents of laboratories, medical stores, general stores, CSSD stores and OT stores should not be kept unsecured on shelves and in racks as it will fall down and break during earthquakes. To mitigate this risk is not difficult; once the racks and cupboards have been anchored to the wall, the contents can easily be secured by using strapping thus preventing chemical bottles and medicine stored on the shelves from falling down.

Strapping 1:2

Chemical and medicine bottles on shelves pose a risk of falling.



Strapping 2:2

Strapping the shelves by nylon rope after anchoring the rack to the wall is an easy way of making these bottles safe.

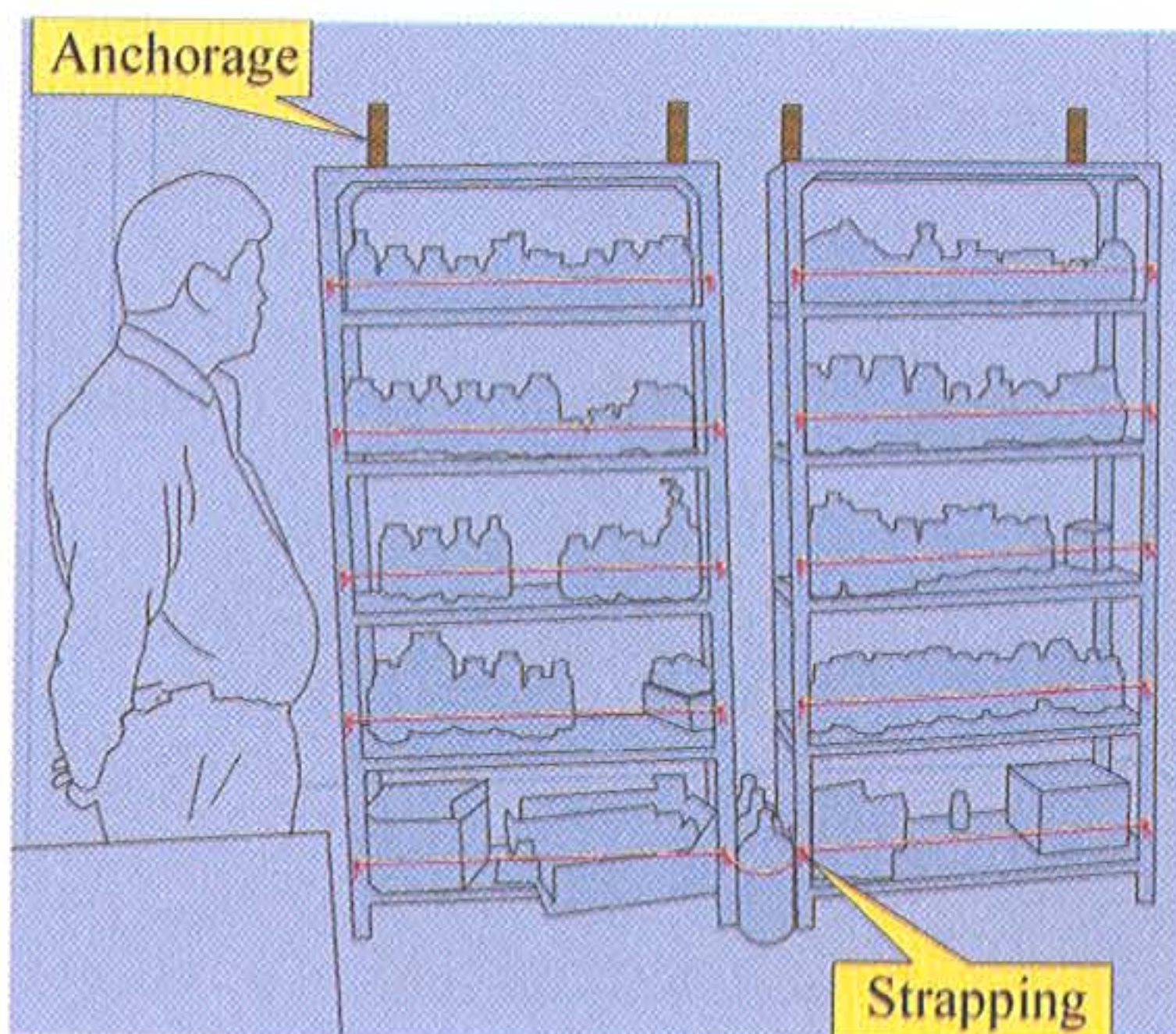

Substitution

Substitution with something that does not represent a seismic hazard is appropriate in some situations. For example, a heavy, tiled roof does not only make the roof of a building heavy, it is also more susceptible to the movement of an earthquake. The individual tiles tend to come off thus creating a hazard for people and objects. One solution would be to change it with a lighter, safer roofing material.

Supports

Supports are suitable in many cases. For example, ceilings are usually hung from cables that only withstand the force of gravity. When subjected to the horizontal stresses and torsion of an earthquake, they easily fall. They can cause serious injury to people underneath them and obstruct evacuation routes. Extra support by additional wires can protect the ceiling or light fixtures from falling.

Supports 1:2

This type of fan needs extra support.



Supports 2:2

Extra support to the lighting system.

References

MOH / DHS / EDCD, WHO & NSET, *A Structural Vulnerability Assessment of Hospitals in Kathmandu Valley*, Kathmandu, 2002.

MOH / DHS / EDCD, WHO & NSET, *Non-Structural Vulnerability Assessment of Hospitals in Nepal*, Kathmandu, 2003.

MOH / DHS / EDCD & WHO, *Guidelines on Emergency Preparedness & Disaster Management for Hospitals*, Kathmandu, 2002.

MOH / DHS / EDCD & WHO, *Health Sector Emergency Preparedness & Disaster Response Plan Nepal*, Kathmandu, 2003.

NSET/GeoHazards International, *Kathmandu Valley's Earthquake Scenario*, Kathmandu, 1999.

UN Office for the Coordination of Humanitarian Affairs (OCHA), *United Nations Disaster Assessment Coordination (UNDAC) Mission Report following the Bam Earthquake of December 2003, 26 December 2003 – 9 January 2004*, www.reliefweb.com, 4 Feb 2004